

**BOSCH**

Invented for life

# LB3-PCx50 Premium Cabinet Loudspeakers



- ▶ **High-quality music and speech reproduction**
- ▶ **Weatherized, suited for sheltered outside use**
- ▶ **Prepared for Bosch WLS, EOL and DMY pcb's**
- ▶ **Attachment points for (suspended) mounting, pole mount**
- ▶ **EN54-24 compliant**

The Bosch premium loudspeakers are full range passive loudspeakers for a wide range of applications where high output, wide controlled dispersion and wide frequency are required, as well as the flexibility of mounting inside and sheltered outside.

The Bosch line of large premium loudspeakers consists of two sizes; 12" and 15" models. All models feature a two-way loudspeaker in a molded ABS VO enclosure. The loudspeakers have a 1" compression driver coupled to an impedance transformer with constant directivity characteristics and a direct radiating 12" or 15" loudspeaker.

Typical uses include fixed installations in auditoriums, conference venues, community centers, theaters, areas of assembly, factories multipurpose halls and sports facilities.

A self-restoring protection device protects the high-frequency driver against incidental overload. The transformer accepts signals between 40 Hz and 22 kHz at 100 V or 70 V.

## System Overview

The LB3-PC250 features a 12"woofer and 1"exit compression driver. The LB3-PC350 features a 15"woofer and 1" exit compression driver.

The premium loudspeaker is fitted with a specially designed horn that provides constant coverage independent of frequency. The handle locations and position of rig-points are placed to make the loudspeaker easy to carry and align when installing. There is an integrated pole mount on the bottom of the cabinet and a weather-resistant steel grille. All screws and bolts are stainless steel or treated to resist rust. The cabinet has been designed to provide the possibility of mounting the loudspeaker close to a side wall or on the floor. The enclosure features high dampening, is impact resistant and weather proof (sheltered).

The LB3-PC250 and LB3-PC350 are suited for locations where high sound pressure, wide-band audio is needed and where there is no mains power or where active loudspeakers are not desired, like outside applications or applications where the benefits of the 100 V technique comes into play like easy connection of multiple speakers and long cable runs.

The LB3-PC250 and LB3-PC350 have a 100/70 V transformer with power tapping. The speakers are weatherproof (IP44, able to be mounted sheltered outside).

**Functions**

The loudspeaker has two SPEAKON connectors wired in parallel. The input from the SPEAKON is available under a waterproof cover at the rear side of the loudspeaker. To protect against moisture, dirt and tampering a splash proof cover is fitted over the control part of the rear panel. Below the cover you can find the input from the SPEAKON, you can choose to wire either channel 1 or channel 2 to the ceramic terminal block. Alternatively it is possible to wire E30 wire directly through PG11 waterproof feed through to the ceramic block (with thermal fuse). The loudspeaker has two PG11 locations to enable loop-through of direct wires. From the ceramic block it is possible to select the speaker tapping. Full, half and quarter power is available at 100 V and 70 V.

The cover has a dedicated location for the EOL (End Of Line) LED, if the Bosch EOL pcb is used, the Bosch proprietary line supervision set for individual loudspeaker monitoring or line monitoring can also be used at this location. Internally the loudspeaker has a dedicated notch filter to filter out a 20 kHz pilot-tone. This will reduce the 20 kHz pilot-tone. The filter is bypassed by a bridge as standard delivery.

Safety features include a thermal fuse in the transformer, thermal fuse at the ceramic input block in accordance with evacuation standards and an auto resetting current limiting circuit between the HF filter output and the HF driver.

The coverage of the speaker is 90° x 60° (H x V).

Wires are connected from the drivers to the metal rear panel, where a hoist/tether point for safety wire is located.

**Certifications and Approvals**

All Bosch loudspeakers are designed to withstand operating at their rated power for 100 hours in accordance with IEC 268-5 Power Handling Capacity (PHC) standards. Bosch has also developed the Simulated Acoustical Feedback Exposure (SAFE) test to demonstrate that the speakers can withstand two times their rated power for short durations. This ensures extra reliability under extreme conditions, leading to greater customer satisfaction, longer operating life, and much less chance of failure or performance deterioration.

Safety	According to EN 60065
EVAC	According to BS 5839-8
	According to EN 60849
Water and dust protection	According to EN 60529 IP44
Self-extinguishing ABS	According to UL 94 V 0

**Installation/Configuration Notes**

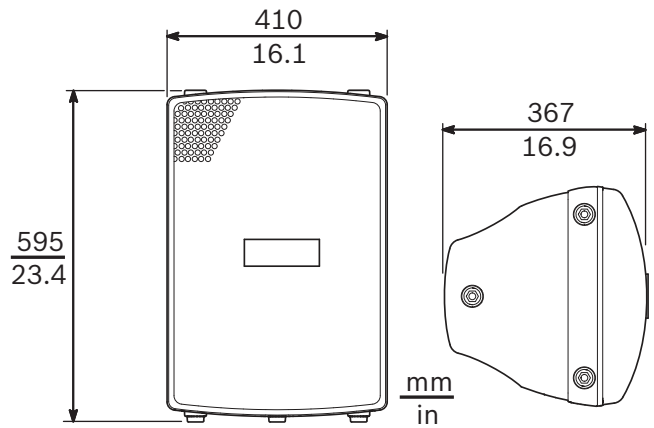

Dimensions LB3-PC250

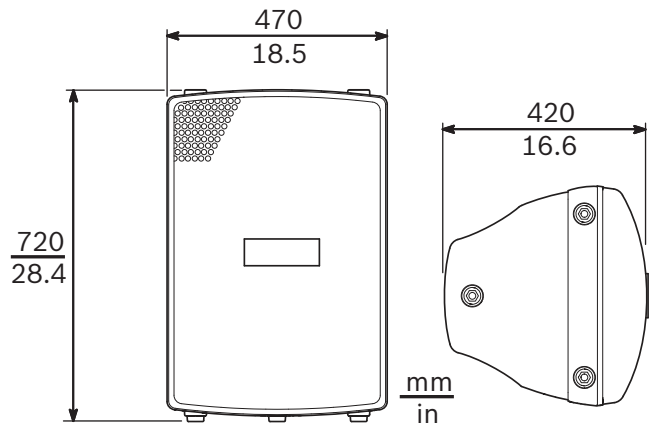

Dimensions LB3-PC350

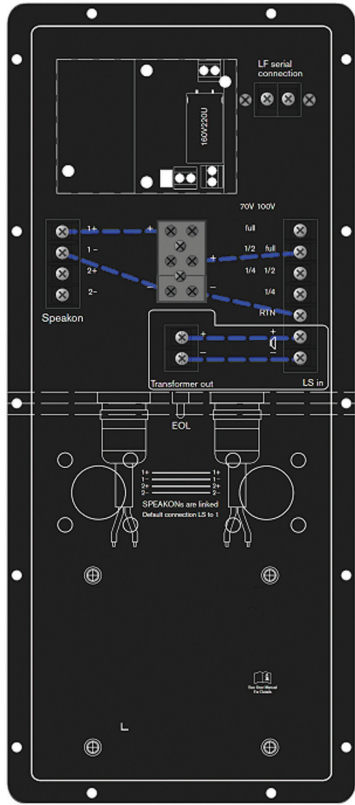

Connection panel on the rear side

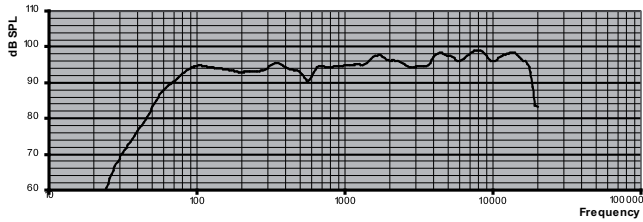

Frequency response LB3-PC250

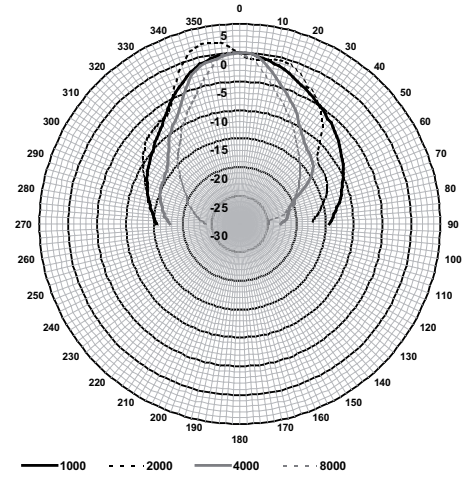

Vertical polar diagrams of LB3-PC250 (pink noise octave, normalized at 0° axis)

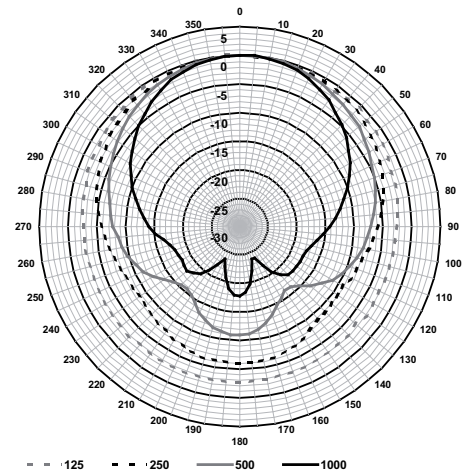

Horizontal polar diagrams of LB3-PC250 (pink noise octave, normalized at 0° axis)

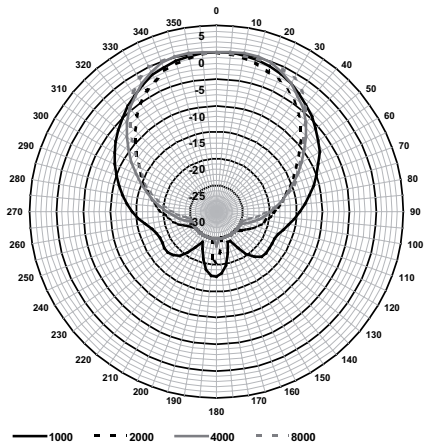
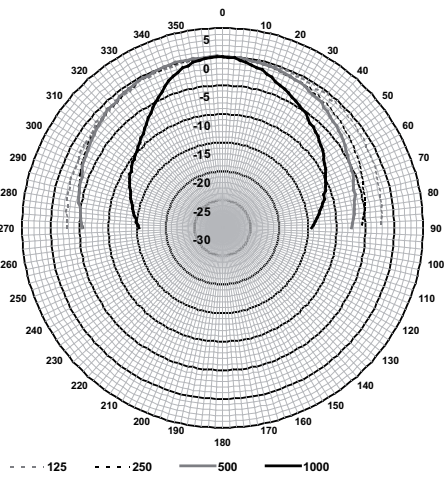

Octave band sensitivity\*

	Octave SPL 1W/1m	Total octave SPL 1W/1m	Total octave SPL Pmax/1m
125 Hz	92.8	-	-
250 Hz	93.3	-	-
500 Hz	93.6	-	-
1000 Hz	94.7	-	-
2000 Hz	97	-	-
4000 Hz	96.8	-	-
8000 Hz	98	-	-
A-weighted	-	93.7	-
Lin-weighted	-	95.1	-

Octave band opening angles

	Horizontal	Vertical
125 Hz	360	360
250 Hz	183	180
500 Hz	152	162
1000 Hz	100	70
2000 Hz	77	66
4000 Hz	87	44
8000 Hz	86	32

LB3-PC250. Acoustical performance specified per octave.

\*all measurements are done with a pink noise signal; the values are in dB SPL

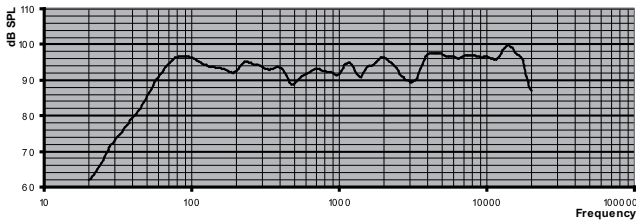

Frequency response LB3-PC350

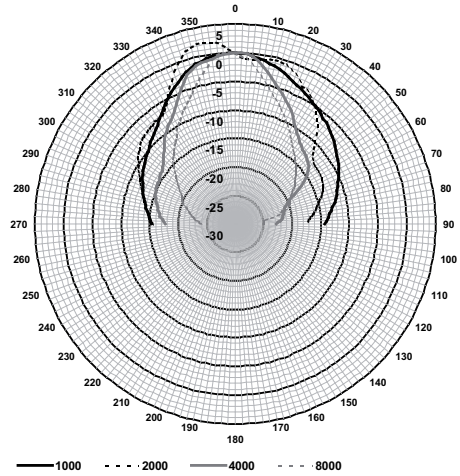
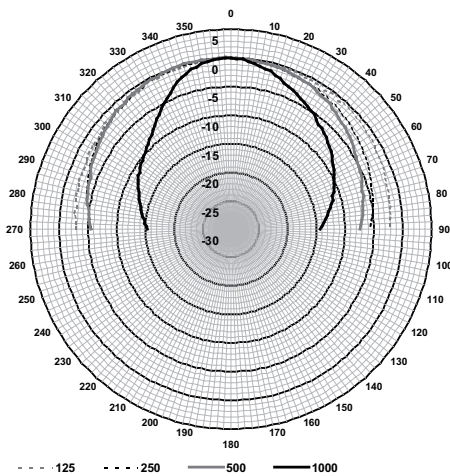

Vertical polar diagrams of LB3-PC350 (pink noise octave, normalized at 0° axis)

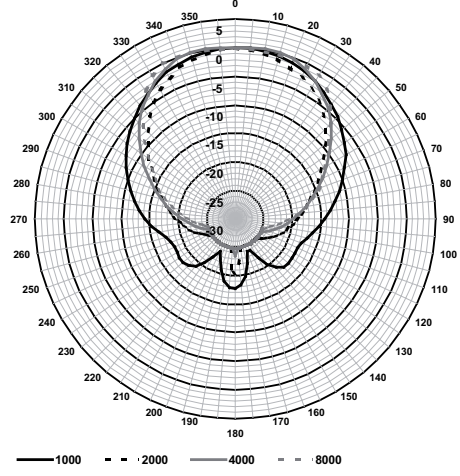
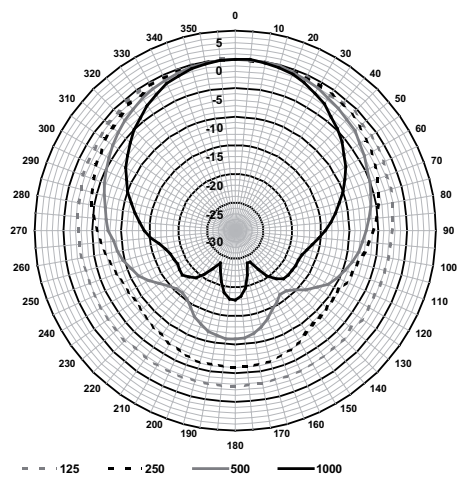

Horizontal polar diagrams of LB3-PC350 (pink noise octave, normalized at 0° axis)

Octave band sensitivity*			
	Octave SPL 1W/1m	Total octave SPL 1W/1m	Total octave SPL Pmax/1m
125 Hz	93.3	-	-
250 Hz	93.8	-	-
500 Hz	93.0	-	-
1000 Hz	93.6	-	-
2000 Hz	95.2	-	-
4000 Hz	96.6	-	-
8000 Hz	98.4	-	-
A-weighted	-	93.3	-
Lin-weighted	-	95.3	-

Octave band opening angles		
	Horizontal	Vertical
125 Hz	360	360
250 Hz	183	180
500 Hz	152	162
1000 Hz	100	70
2000 Hz	77	66
4000 Hz	87	44
8000 Hz	86	32

LB3-PC350. Acoustical performance specified per octave.

\*all measurements are done with a pink noise signal; the values are in dB SPL

### Parts Included

Quantity	Components
1	LB3-PCx50
1	Installation instruction

### Technical Specifications

#### Electrical\*

Product	LB3-PC250	LB3-PC350
Description	Premium 250 W Cabinet Loudspeaker	Premium 350 W Cabinet Loudspeaker
Maximum power	500 W	700 W
Rated power (PHC)	250 W	350 W
Power tapping	250 / 125 / 62.5 W	350 / 175 / 87.5 W
Sound pressure level at rated power / 1 W (1 kHz, 1 m)	117 dB / 94 dB (SPL)	122 dB / 97 dB (SPL)
Effective frequency range (-10 dB)	55 Hz to 18 kHz	48 Hz to 18 kHz
Opening angle at 1 kHz / 4 kHz (-6 dB)		

horizontal	100° / 87°	100° / 87°
vertical	70° / 44°	70° / 44°
Rated input voltage	70 / 100 V	70 / 100 V
Rated impedance	20 / 40 ohm	14 / 29 ohm

\* Technical performance data acc. to IEC 60268-5

#### Mechanical

Product	LB3-PC250	LB3-PC350
Dimensions (WxDxH)	410x367x595 mm (16.1x16.9x23.4 in)	470x420x720 mm (18.5x16.6x28.4 in)
Connectors	SPEAKON	SPEAKON
	3-pole ceramic screw block	3-pole ceramic screw block

Loudspeaker diameter		
Woofer	305 mm (12 in)	381 mm (15 in)
Driver	25.4 mm (1 in)	25.4 mm (1 in)

Material		
Cabinet	ABS VO	ABS VO
Front grille	Powder coated steel	Powder coated steel
Color	Charcoal (RAL 7021) (D)	Charcoal (RAL 7021) (D)
Weight	19 kg (42 lb)	34 kg (74 lb)

#### Environmental

Operating temperature	-10 °C to +40 °C (-14 °F to +104 °F)
Storage temperature	-40 °C to +70 °C (-40 °F to +158 °F)
Relative humidity	<95%

### Ordering Information

**LB3-PC250 Premium 250W Cabinet Loudspeaker**      **LB3-PC250**  
12", 250 W premium loudspeaker

**LB3-PC350 Premium 350W Cabinet Loudspeaker**      **LB3-PC350**  
15", 350 W premium loudspeaker

**Americas:**

Bosch Communications Systems  
12000 Portland Avenue South  
Burnsville, Minnesota 55337, USA  
Phone: +1-800-392-3497  
Fax: +1-800-955-6831  
audiosupport@us.bosch.com  
www.boschsecurity.com

**Europe, Middle East, Africa:**

Bosch Security Systems B.V.  
P.O. Box 80002  
5600 JB Eindhoven, The Netherlands  
Phone: +31 40 2577 284  
Fax: +31 40 2577 330  
emea.securitysystems@bosch.com  
www.boschsecurity.com

**Asia-Pacific:**

Robert Bosch (SEA) Pte Ltd  
11 Bishan Street 21  
Singapore 573943  
Phone: +65 6571 2600  
Fax: +65 6571 2698  
apr.securitysystems@bosch.com  
www.boschsecurity.com

**Represented by**