

BOSCH

Invented for life

LP1-UC10E-1 Unidirectional Sound Projector



- ▶ **Superb speech and music reproduction**
- ▶ **Integrated connection cable**
- ▶ **Ceiling or wall mounting**
- ▶ **Water and dust protected to IP 65**
- ▶ **BS 5839-8 and EN 60849 compliant**

The LP1-UC10E-1 is a powerful, 10 W sound projector intended for high quality speech and music reproduction in indoor and outdoor applications. The state-of-the-art design is matched to both modern and traditional style environments. The sound projector is suitable for use in voice alarm systems.

be used to inform people of the situation. The loudspeaker has a ceramic terminal block, thermal fuse and heat resistant, high-temperature wiring.

The sound projector is made from high-impact self-extinguishing ABS according to class UL 94 V0, finished in white.

Functions

Superb sound quality

The use of a high-quality driver in combination with advanced filtering has resulted in a very natural sound reproduction with excellent bass response.

Voice alarm loudspeaker

Voice alarm loudspeakers are specifically designed for use in buildings where performance of systems for verbal communication announcements is governed by regulations. The LP1-UC10E-1 is designed for use in voice alarm systems. The sound projector is pre-wired for use with an optional line/loudspeaker supervision board external mounted. The loudspeaker has built-in protection to secure that, in the event of a fire; damage to the loudspeaker does not result in failure of the circuit to which it is connected. In this way, system integrity is maintained; ensuring loudspeakers in other areas can still

Certifications and Approvals

Quality assurance

All Bosch loudspeakers are designed to withstand operating at their rated power for 100 continuous hours in accordance with IEC 268-5 Power Handling Capacity (PHC) standards. Bosch has also developed the Simulated Acoustical Feedback Exposure (SAFE) test to demonstrate that they can withstand two times their rated power for short durations. This ensures improved reliability under extreme conditions, leading to higher customer satisfaction, longer operating life, and lessens the chance of failure or performance deterioration.

Safety aspects

In common with all Bosch products, care is taken to meet high safety standards. All ABS parts are self-extinguishing (according to UL 94 V 0). This sound projector complies with the relevant safety and installation regulations of EN 60065, BS 5839-8 and EN 60849.

Region	Certification
Europe	CE
Poland	CNBOP
Water and dust protection	according to IEC 60529, IP 65
Emergency	according to BS 5839-8 / EN 60849

Installation/Configuration Notes

Mounting

Ease of installation is realized in the way of mounting: first the mounting plate is fixed to the wall or ceiling, secondly a safety cord is attached to the mounting plate, allowing the installer temporarily hang the loudspeaker during installation. After making the connections, the sound projector can be fixed to the mounting plate, by means of a fixing screw nut, and the horizontal direction can be fixed. A cover plate covers screws and electrical wiring. The versatile mounting bracket allows the sound projector to be horizontal and vertical directed. The vertical direction can be permanent fixed with a recessed socket head screw via a small hole located in the rear housing. The cover plate is provided with two cable – or 16 mm (0.63 inch) conduit entries (covered as standard supplied) in opposite position, suitable for loop-through cabling.

Power setting

A ceramic terminal for electrical connection is provided. The loudspeaker is standard connected to full power. Half-power, quarter-power or eighth-power can be selected by connecting the appropriate color-coded wire to the terminal block.

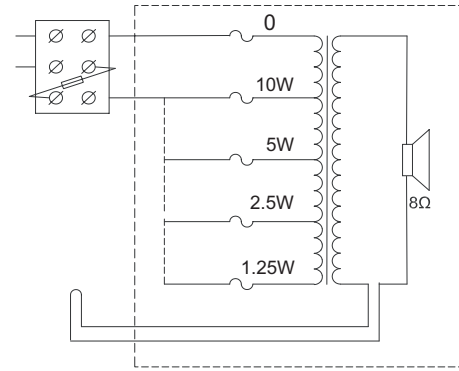

Circuit diagram

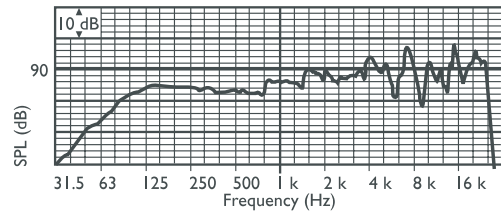

Frequency response

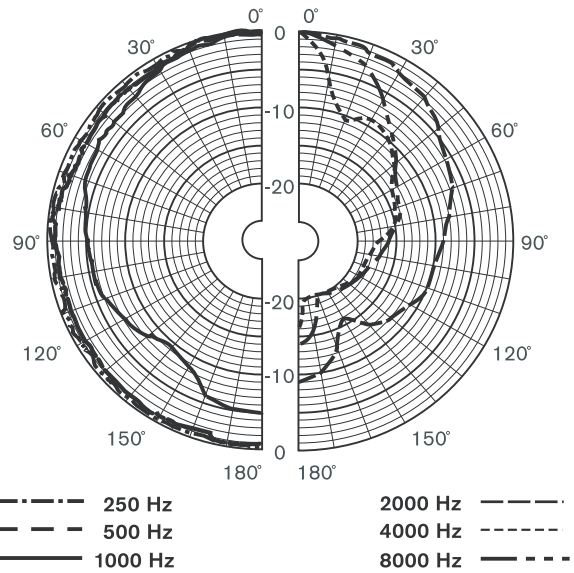

Polar diagram (measured in pink noise)

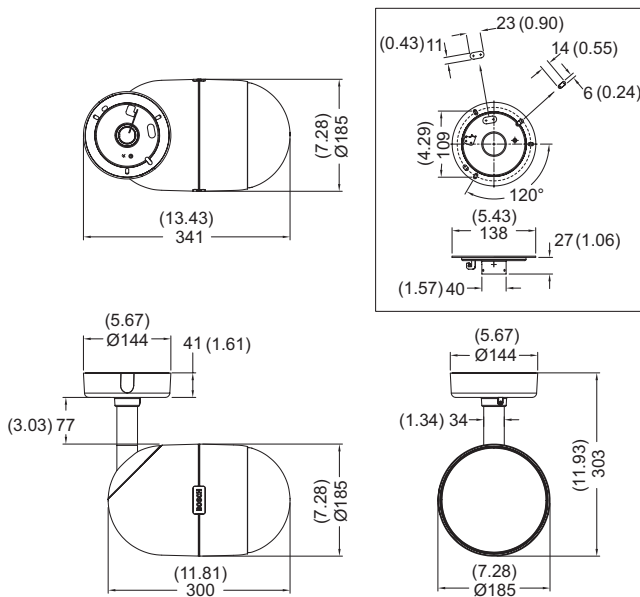

Dimensions in mm / (in)

	Octave band sensitivity*		
	Octave SPL 1W/1m	Total octave SPL 1W/1m	Total octave SPL Pmax/1m
125 Hz	84.0	-	-
250 Hz	84.3	-	-
500 Hz	84.4	-	-
1000 Hz	86.0	-	-
2000 Hz	89.4	-	-

4000 Hz	91.1	-	-
8000 Hz	94.3	-	-
A-weighted	-	88.2	97.7
Lin-weighted	-	89.9	98.8
Octave band opening angles			
	Horizontal	Vertical	
125 Hz	360	360	
250 Hz	360	360	
500 Hz	360	360	
1000 Hz	224	224	
2000 Hz	124	124	
4000 Hz	63	63	
8000 Hz	35	35	

Acoustical performance specified per octave * (all measurements are done with a pink noise signal; the values are in dBSPL).

Technical Specifications

Electrical*

Maximum power	15 W
Rated power	10 / 5 / 2.5 / 1.25 W
Sound pressure level at 10 W / 1 W (1 kHz, 1 m)	96 dB / 86 dB (SPL)
Opening angle at 1 kHz / 4 kHz (-6 dB)	220° / 65°
Effective frequency range (-10 dB)	75 Hz to 20 kHz
Rated voltage	100 V
Rated impedance	1000 ohm
Connector	3-pole screw terminal

* Technical performance data according to IEC 60268-5

Mechanical

Dimensions (D x L)	185 x 300 mm (7.3 x 11.8 in.)
Weight	3 kg (6.6 lb)
Color	White (RAL 9010)
Material	ABS

Environmental

Operating temperature	-25 °C to +55 °C (-13 °F to +131 °F)
Storage temperature	-40 °C to +70 °C (-40 °F to +158 °F)
Relative humidity	<95%

Ordering Information

LP1-UC10E-1 Unidirectional Sound Projector	LP1-UC10E-1
10 W, white ABS	

Americas:

Bosch Communications Systems
12000 Portland Avenue South
Burnsville, Minnesota 55337, USA
Phone: +1-800-392-3497
Fax: +1-800-955-6831
audiosupport@us.bosch.com
www.boschsecurity.com

Europe, Middle East, Africa:

Bosch Security Systems B.V.
P.O. Box 80002
5600 JB Eindhoven, The Netherlands
Phone: +31 40 2577 284
Fax: +31 40 2577 330
emea.securitysystems@bosch.com
www.boschsecurity.com

Asia-Pacific:

Robert Bosch (SEA) Pte Ltd
11 Bishan Street 21
Singapore 573943
Phone: +65 6571 2600
Fax: +65 6571 2698
apr.securitysystems@bosch.com
www.boschsecurity.com

Represented by