



LS1-UC20E-1 Pendant Sphere Loudspeaker



- ▶ **Superb speech and music reproduction**
- ▶ **5 m connection cable**
- ▶ **Provision for optional safety cord**
- ▶ **Water and dust protected to IP 65**
- ▶ **BS 5839-8 and EN 60849 compliant**

Sound spheres are pendant sound projectors designed to be suspended from the ceiling by their connecting cables. Their excellent sound spread makes them ideal for use in buildings with high ceilings, such as supermarkets and superstores.

The LS1-UC20E-1 is a powerful 20 W pendant sphere loudspeaker, intended for high quality speech and music reproduction. The state-of-the-art design is matched to both modern and traditional style environments. The loudspeaker is suitable for use in voice evacuation systems.

The loudspeaker has built-in protection to ensure that, in the event of a fire, damage to the loudspeaker does not result in failure of the circuit to which it is connected. In this way, system integrity is maintained; ensuring loudspeakers in other areas can still be used to inform people of the situation. The loudspeaker is supplied with a ceramic terminal block and thermal fuse.

Superb Sound Quality

The use of a high-quality driver in combination with advanced filtering, have resulted in a very natural sound reproduction with excellent bass response.

Functions

Voice Alarm Loudspeaker

Voice alarm loudspeakers are specifically designed for use in buildings where performance of systems for verbal communication announcements is governed by regulations. The LS1-UC20E-1 is designed for use in voice alarm systems and is compliant with British Standard BS 5839-8 and EN 60849.

Certifications and Approvals

All Bosch loudspeakers are designed to withstand operating at their rated power for 100 continuous hours in accordance with IEC 268-5 Power Handling Capacity (PHC) standards. Bosch has also developed the Simulated Acoustical Feedback Exposure (SAFE) test to demonstrate that they can withstand two times their rated power for short durations. This ensures improved reliability under extreme conditions, leading to higher customer satisfaction, longer operating life, and lessens the chance of failure or performance deterioration.

Safety Aspects

In common with all Bosch products, care is taken to meet high safety standards. All ABS parts are self-extinguishing (according to UL 94 V 0). This sound projector complies with the relevant safety and installation regulations of EN 60065.

Region	Certification
Europe	CE
Water and dust protection	according to IEC 60529, IP 65
Emergency	according to BS 5839-8 / EN 60849

Installation/Configuration Notes

Mounting

The loudspeaker is suspended from the ceiling via its five meter, five-core connecting cable, which is easy to shorten for the desired height. For optional safety, a steel safety cord can be attached.

Power Setting

The loudspeaker is supplied with a five meter color-coded, five-core connecting cable with each color connected to a different primary tap on the 100 V matching transformer. This allows nominal full-power, half-power, quarter-power or eighth-power radiation to be selected (in 3 dB steps).

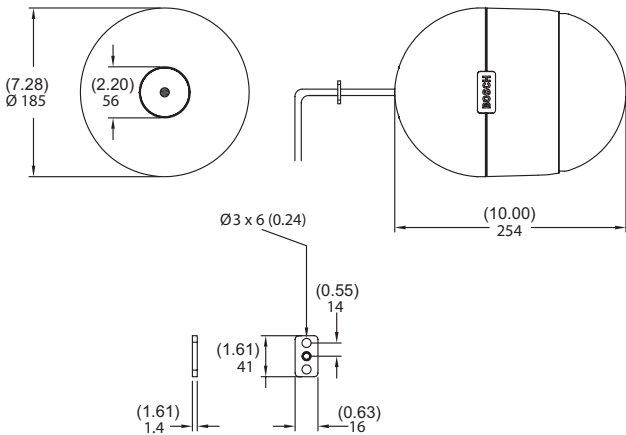

Dimensions in mm / (in)

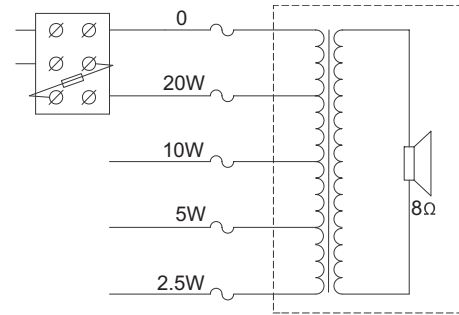

Circuit diagram

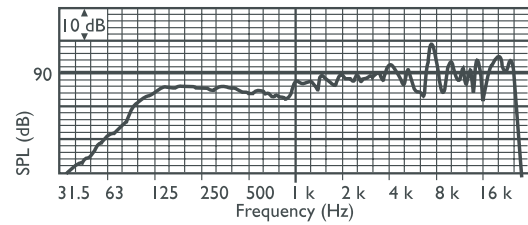

Frequency response

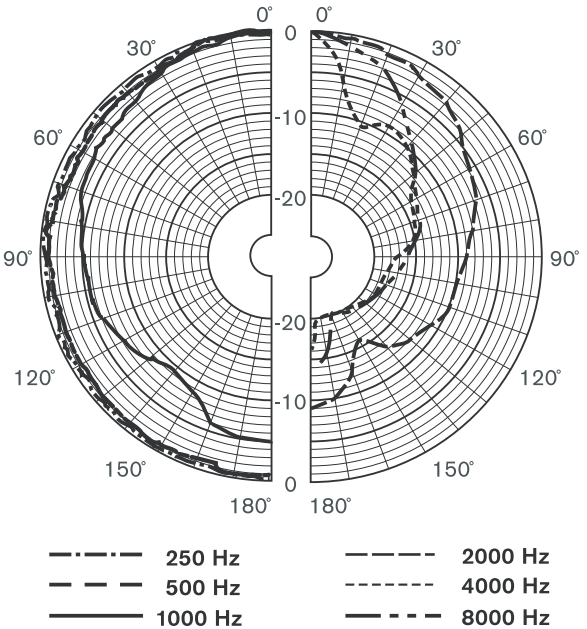

Polar diagram (measured with pink noise)

Octave band sensitivity*	Octave band sensitivity*		
	Octave SPL 1W/1m	Total octave SPL 1W/1m	Total octave SPL Pmax/1m
125 Hz	84.1	-	-
250 Hz	84.7	-	-
500 Hz	84.3	-	-
1000 Hz	85.3	-	-
2000 Hz	88.3	-	-

4000 Hz	90.7	-	-
8000 Hz	90.7	-	-
A-weighted	-	87.4	99.3
Lin-weighted	-	89.4	101.0
Octave band opening angles			
	Horizontal	Vertical	
125 Hz	360	360	
250 Hz	360	360	
500 Hz	360	360	
1000 Hz	220	220	
2000 Hz	122	122	
4000 Hz	67	67	
8000 Hz	37	37	

Acoustical performance specified per octave * (all measurements are done with a pink noise signal; the values are in dB SPL).

Parts Included

Quantity Components

1	LS1-UC20E-1 Pendant Sphere Loudspeaker
1	Cable clamp

Technical Specifications

Electrical*

Maximum power	30 W
Rated power	20 / 10 / 5 / 2.5 W
Sound pressure level at 20 W / 1 W (1 kHz, 1 m)	99 dB / 86 dB (SPL)
Opening angle at 1 kHz / 4 kHz (-6 dB)	220° / 65°
Effective frequency range (-10 dB)	80 Hz to 20 kHz
Rated voltage	100 V
Rated impedance	500 ohm
Connector	3-pole screw terminal

* Technical performance data acc. to IEC 60268-5

Mechanical

Dimensions (D x L)	185 x 254 mm (7.3 x 10 in)
Weight	3 kg (6.6 lb)
Color	White (RAL 9010)
Material	ABS

Environmental

Operating temperature	-25 °C to +55 °C (-13 °F to +131 °F)
Storage temperature	-40 °C to +70 °C (-40 °F to +158 °F)
Relative humidity	<95%

Ordering Information

LS1-UC20E-1 Pendant Sphere Loudspeaker
20 W, white ABS

LS1-UC20E-1

Americas:

Bosch Communications Systems
12000 Portland Avenue South
Burnsville, Minnesota 55337, USA
Phone: +1-800-392-3497
Fax: +1-800-955-6831
audiosupport@us.bosch.com
www.boschsecurity.com

Europe, Middle East, Africa:

Bosch Security Systems B.V.
P.O. Box 80002
5600 JB Eindhoven, The Netherlands
Phone: +31 40 2577 284
Fax: +31 40 2577 330
emea.securitysystems@bosch.com
www.boschsecurity.com

Asia-Pacific:

Robert Bosch (SEA) Pte Ltd
11 Bishan Street 21
Singapore 573943
Phone: +65 6571 2600
Fax: +65 6571 2698
apr.securitysystems@bosch.com
www.boschsecurity.com

Represented by